

## PRINTING SETUP with OMEGA ENLARGER

Follow this procedure when beginning a work session in the Darkroom.  
Use this page as an actual checklist as you prepare to work.

Get a key from the Monitor in the Cage in return for your TU ID card.  
Unlock both drawers.  
Key A is for the large drawer; Key B is for the small drawer.

### PRINTING SETUP

Lens selection                    **for a medium print on 11 x 14" paper**

- Insert the **80mm lens** from the Small Drawer into the Enlarger  
open the aperture (brighter) for easier focusing

Condenser position

- Set the Condenser on the **bottom shelf**

Bellows position

- Set the Bellows to **top position**

Carriage location

- Move the Carriage to **~29 cm**

Timer Power

- Turn the Timer **on** with the back switch

Easel Position

- Get the Printing Easel out of the Large Drawer  
Position it below the lens  
Slide the arms to 8 x 12", then move up half a notch

Negative Carrier

- Get a filed-out negative carrier [from the Cage if necessary]  
Put the desired negative into the carrier  
Dust off the negative with compressed air at the back of the Darkroom

Focus adjustment

- Adjust the focus for your negative  
Both focus and carriage position determine the final print size  
Adjust by eye first, then use the Grain Magnifier to fine-tune

Contrast Filter placement

- Place a **#2 Contrast Filters** into the Condenser Drawer to Start  
after the negative is focused (easier when brighter)  
Change filter to adjust contrast range

Test Strip

- Make a test print that includes the highlights and shadows of the print

Make a print

- Make a final print once the proper exposure and contrast is determined

## OMEGA ENLARGER SETUP, theory

There are 6 settings to be considered to make a print with an Omega Enlarger:

- Lens selection, Condenser position, Bellows position,
- Carriage movement, Focus adjustment and Contrast Filter placement.

### LENS SELECTION

- Insert the desired Lens into the enlarger
  - Pull the Focus down a bit to make insertion easier
  - Hold the Lensboard by the end with the hole
- Lenses are stored in the smaller drawer on the right-hand side
  - Several lenses are available, including:
    - 50mm for 35mm film
    - 75 or 80mm for Medium Format film, or Medium size prints from 35mm film
    - 135mm lenses for Large Format film, or Small prints from 35mm film

All enlarger stations should have all 3 lenses.  
Some enlargers have turrets with 3 lenses mounted on them.





The turret rotates by pressing gently on the small silver lever that protrudes from the front right side of the lensboard.

Turn the turret until the desired lens clicks *firmly* into place.

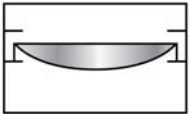

### CONDENSER POSITION

This is the chart that is inside the Condenser Chamber in the Enlarger Head. It shows the proper position for each length of lens.

| 150mm LENS   | 135mm LENS  | 90mm TO 105mm LENSES   | 80mm AND SHORTER LENSES   |
|--|---|--|---|
|  <p style="margin-top: 5px;"><b>REMOVE<br/>CONDENSER<br/>ENTIRELY</b></p> |  |  |  |

Make sure the Condenser is inserted into the Enlarger with the small lip at the front (and not upside down, as we have sometimes found them).

- Return the Condenser to the 'default location' [bottom shelf] when finished working.

## OMEGA ENLARGER SETUP, theory cont'd

### BELLOWS POSITION

The bellows position changes for each length lens.

|                  |                     |                |
|------------------|---------------------|----------------|
| short 50mm lens  | top of the track    | position 14 cm |
| medium 75mm lens | middle of the track | position 7 cm  |
| long 135mm lens  | bottom of track     | position 0 cm  |

### Adjusting the Bellows

There is a lever, back behind the lens that has to be shifted from left to right to release the lens bellows.

This is a delicate procedure!

place \_\_\_\_\_ your hand under the lens to reflect light back onto the Bellows Track

place \_\_\_\_\_ your hand under the lens so it does not fall straight down do not allow your hand to touch the front glass surface of the lens

turn \_\_\_\_\_ the **BELLOWS LEVER** under and behind the lens to the right

gently move \_\_\_\_\_ the **BELLOWS** itself to the correct position

turn \_\_\_\_\_ the **BELLOWS LEVER** back to the left to lock it



- Return the Bellows to the 'default location' [top] when finished working.

### CARRIAGE MOVEMENT

The entire carriage of the enlarger is moved using the crank on the right hand side of the enlarger.

unloosen \_\_\_\_\_ the **CARRIAGE LOCK** at the bottom right of the enlarger

crank \_\_\_\_\_ the **CARRIAGE** to the desired position

tighten \_\_\_\_\_ the **CARRIAGE LOCK** to just finger-tight

**Do Not over-tighten the Carriage Locks,**  
they only have nylon teeth!

- Return the Carriage to the 'default location' [20 cm] when finished working.

### FOCUS ADJUSTMENT

The focus is fine-tuned with the **FOCUS KNOB** on the right-hand side of the enlarger.

turn \_\_\_\_\_ the **FOCUS KNOB** on the right

Altering the focus also changes the size of the picture. Sometimes the perfect balance of focus and picture size is achieved by adjusting the focus and the carriage height to compliment each other.

### CONTRAST FILTERS PLACEMENT

Large flat contrast filters are placed into the Condenser Chamber

Handle only by the edges

Start with a #2 Filter for 'Normal Contrast'

**Do Not open the Condenser Chamber with the Enlarger light turned on!!**

- Return all Contrast Filters to the drawer when finished working.

## OMEGA ENLARGER - SMALL PRINT SETUP

### MEDIUM PRINTS with a MEDIUM LENS

To make an 8 x 12" print on an 11 x 14" sheet of photo paper, adjust these 5 settings as follows:

#### Lens selection

insert a **80mm** LENS into the enlarger  
or turn the turret until the 80mm lens comes into position

#### Condenser position

use the **BOTTOM SHELF** position

#### Bellows adjustment

place your hand under the lens so it does not fall straight down  
turn the bellows lever under and behind the lens to the right  
gently move the Bellows to the correct position  
**BELLOWS HEIGHT = TOP POSITION**  
turn the bellows lever back to the left to lock it

#### Carriage movement

loosen the Carriage Lock at the bottom right of the enlarger  
crank the **CARRIAGE TO ~29**  
tighten the Carriage Lock to just finger-tight  
**Do Not over-tighten the Carriage Locks,**  
they only have nylon teeth!

#### Focus adjustment

use the **FOCUS KNOB** on the right  
fine tune the picture size by adjusting both the focus and carriage height

### SMALL PRINTS with a LONG LENS

To make an 4 x 6" print, adjust these 5 settings as follows:

Lens = 135mm  
Condenser = the **TOP** shelf  
Bellows = 5 (middle)  
Carriage = ~35cm

The smallest print possible with a 80mm lens is 5.5 x 8".

Lens = 80mm  
Condenser = the middle shelf  
Bellows = 11 (near the top)  
Carriage = all the way down

A 3.5 x 5" print is easily attainable by moving the Carriage down to about 28, with all other settings the same.

It is possible to make even small prints, if desired. A 1 x 1.5" print, equal to the size of the negative itself, is possible with a 135mm lens in an enlarger with the Carriage adjusted all the way down, and the Bellows set at 2.

#### Easel Position

Another option for making small prints is to raise the easel up toward the lens, as it states in the Omega User's Manual. Simply place a box that will sturdily support the easel underneath. Voila!

## GRALAB 450 TIMER – Operation

### TIME RANGE

The timer can be set for seconds or 1/10ths of seconds.

**SECS**☆ the range is from 00 to 99 seconds  
the left-hand button is 10's of seconds, the right-hand button is seconds

**1/10 SECS** the range is 0.0 to 9.9 seconds  
the left-hand button is seconds, the right-hand button is 10ths of seconds

### DISPLAY INTENSITY

3 buttons choose between **HI**☆ **DIM** **OFF**

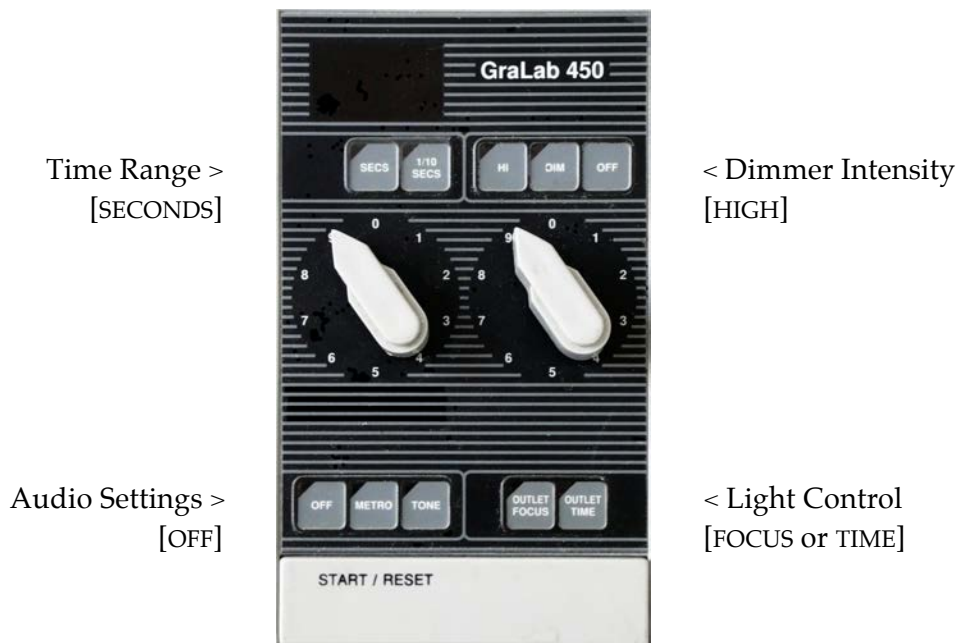

### AUDIO SETTINGS

3 buttons choose between

**OFF**☆ no sound - preferred  
**METRO** metronome beeps at every second  
**TONE** beeps at the end of the exposure

### LIGHT CONTROL

**FOCUS** keeps the enlarger on indefinitely (left-hand button)  
**TIME** enters timer mode (right-hand button)

### START/ STOP/ RESET BAR

Hit this bar to **START** and **STOP** the timing cycle, to make a print.

Hitting the bar during an exposure **stops** the enlarger,  
and resets the time back to the original time setting.

The timer **always** resets back to the original time after an exposure.

## ENLARGER SHUTDOWN

Follow this procedure when finished a work session in the Darkroom.  
Use this page as an actual checklist as you shut down.

### ENLARGER

Lens selection

- Place all lenses in the small Drawer, side by side, not stacked on top

Condenser position

- Return the Condenser to the 'default location' [bottom shelf]

Bellows position

- Return the Bellows to the 'default location' [top]

Carriage location

- Return the Carriage to the 'default location' [20 cm]

Focus adjustment

- Pull the focus back up, but not quite all the way

Contrast Filter placement

- Return all Contrast Filters to their package then put them back in the small Drawer

Enlarger Mouth

- Close the mouth of the enlarger, to keep out any dust

Timer Power

- Turn the Timer off with the back switch

### DRAWERS

The Enlarger Drawers should contain the basic complement of tools.  
Check that everything is there:

Large Drawer

- Printing Easel

Small Drawer

- Negative Carriers [return filed-out carriers to the Cage]
- Contrast Filters
- Lenses, single or on a turret
- Grain Magnifier

Shelf

- Glass Contact Frame

Lock both drawers when finished and return the key to the Monitor in the Cage.

## PRINTING PROTOCOL

**write** your **name, your class** and the **date** on the back of each print  
*before* you process it in the photo chemicals

**write** the exposure; *f* / stop, time and filter number  
on the back of the print as well

write small, along the edge,  
to avoid compromising the archival quality of the print  
using either pencil or a Sharpie  
(never an ink pen that will contaminate the chemistry)

**develop, stop** and **fix**  
as prescribed by the paper manufacturer  
(read the data sheet that comes with the paper for exact times,  
every paper is slightly different)

do a **short wash** at the end of the processing in the Darkroom

**transport** all prints to the Finishing Sinks using a **print viewing tray**

**rinse** all prints from the printing session for 3 minutes  
in the **print viewing tray** with running water

put all prints through the **fixer-remover bath** for another 3 minutes

**rinse** all prints in water again for 3 minutes to remove all **fixer-remover**  
do not place prints directly into the print washer  
if they still have fixer-remover on them

do a **final wash** in the vertical archival washer for at least 30 minutes  
never add prints to a washing session already in progress  
the wash time will have to start all over again

*do not save* your test strips *do*  
*not save* your test prints

only place **fully archival prints** on the screens to dry  
or take damp prints home in a blotter book  
dry them on a clothes line, pinned back to back at all 4 corners,

**pick up** all prints the next day, preferably in the morning  
any print left longer than 1 day will be discarded  
there is not enough room on the screens  
this is not a storage facility

**flatten** prints under a stack of books  
or in a dry mount press, at low temperature  
between 2 sheets of archival drawing paper